

OPERATION MANUAL

26" Rigging Sheave

Manufactured by Wireline Technologies, Inc.



Serial Number _____

Introduction

This manual explains the use and care of 26” rigging sheaves manufactured by Wireline Technologies, Inc. The sheave is available in two models. The original model with shielded bearings, identified by an orange cover, and the sealed bearing model, identified by a yellow cover. Each is available in two configurations. The no-shroud configuration, shown in figure 1, will allow a rope socket or “torpedo” to pass over the wheel. The half-shroud configuration, shown in figure 2, has a cable shroud covering part of the wheel to aid in containing the line in the wheel groove. Please read and become familiar with all of the information in this manual before using this equipment.



No-Shroud (Standard)
Figure 1



Half-Shroud (Optional)
Figure 2

! WARNINGS !

- Read entire manual before operating this equipment.
- If proper procedures are not followed, loads may disengage.
- A falling load can cause serious injury or death.
- Never use this product for hoisting personnel.
- Always anchor or hang the sheave via the clevis, never by way of the cover or any ancillary equipment.
- Never apply more force than the Safe Working Load (SWL) listed on the affixed tag.
- The listed Safe Working Load is for the sheave assembly; the safe line tension will be less.
- Attachment to other equipment with lower SWL will reduce the allowable load.
- Always use a hand guard when the sheave is used around personnel.
- Always make sure the sheaves are properly maintained and properly rigged.

Safe Working Load

The rated safe working load (SWL) for a WTI 26" sheave is dependent upon the swivel clevis assembly attached, see page 3. The allowable line pull will depend upon both the SWL and the angle the line is deflected. If the sheave is used as a top sheave, it deflects the line 180°, see figure 3. If the sheave is used as a bottom sheave, it deflects the line 90°, see figure 4. Never exceed the SWL, unless special precautions are taken in accordance with your company's policy. These precautions should include, but are not limited to, clearing the rig floor of all personnel. If the SWL is exceeded, the sheave should be re-certified before it can safely be placed back in service.

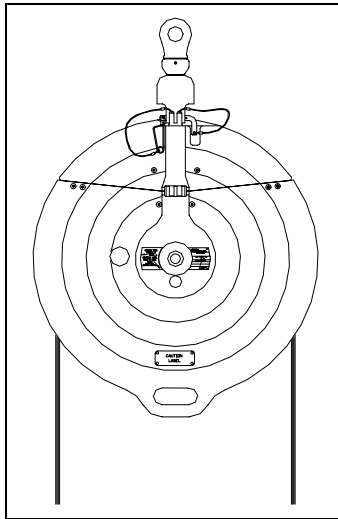

Top Sheave **Max. Line Tension**

Clevis-Eye
10,000 lbs (4,530 kg)

Clevis-AWS
16,000 lbs (7,250 kg)

Clevis-HLS
12,000 lbs (5,440 kg)

Clevis-SJ
10,000 lbs (4,530 kg)

Clevis-Shackle
16,000 lbs (7,250 kg)

Safe Line Tension for 180-Degree Deflection
Figure 3

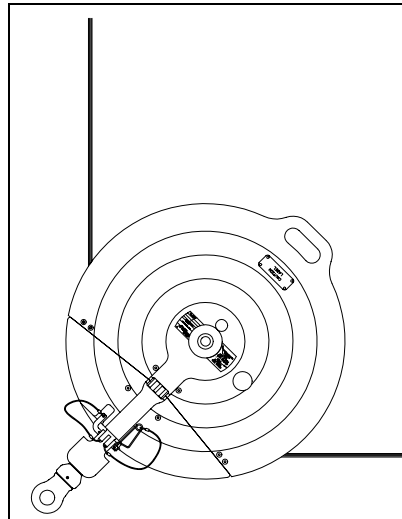

Bottom Sheave **Max. Line Tension**

Clevis-Eye
14,140 lbs (6,410 kg)

Clevis-AWS
22,620 lbs (10,260 kg)

Clevis-HLS
16,970 lbs (7,690 kg)

Clevis-SJ
14,140 lbs (6,410 kg)

Clevis-Shackle
22,620 lbs (10,260 kg)

Safe Line Tension for 90-Degree Deflection
Figure 4

Clevis Options

Five clevis swivel assembly options for suspending/anchoring the sheave are available: These options are shown in figures 5 – 9 below. The Clevis-Eye has an opening about 2.5" X 3.3" for a chain or sling. The opening width of the Clevis -AWS is 1 3/4" with a hole for a 1" pin. The opening width of the Clevis -HLS is 1 1/4" with a hole for a 1" pin. The opening width of the Clevis-SJ is 7/8" with a hole for a 1 1/2" pin. The shackle clevis has about the same opening as the Clevis-Eye but is rated for higher load. Each clevis has its own rated Safe Working Load (SWL). These safe working loads are based on at least a 4:1 safety factor and will determine the safe working load for the sheave assembly.

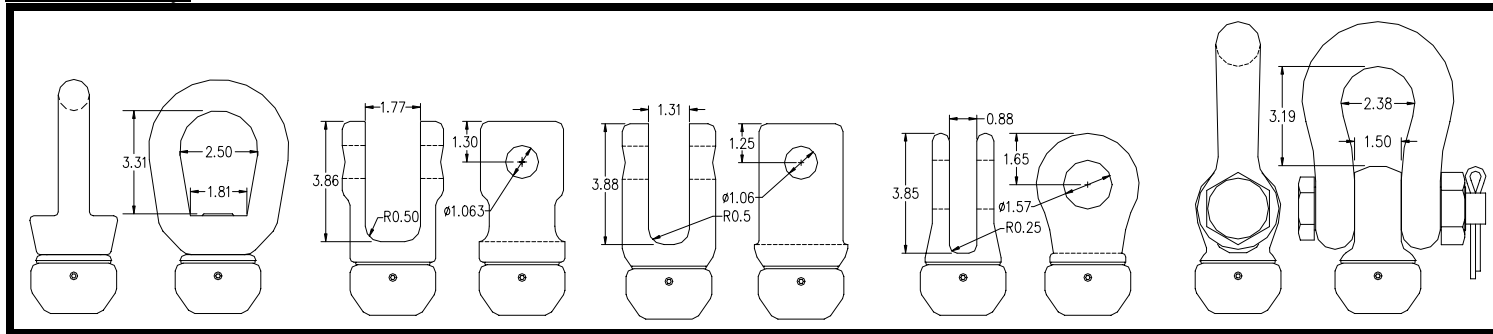

Clevis-Eye
Part # RS-1075A
SWL = 20,000 lbs
(9,070 kg.)
Figure 5

Clevis-AWS
Part # RS-1252A
SWL = 32,000 lbs
(14,510 kg.)
Figure 6

Clevis-HLS
Part # RS-1552A
SWL = 24,000 lbs
(10,880 kg.)
Figure 7

Clevis-SJ
Part # RS-1052A
SWL = 20,000 lbs
(9,070 kg.)
Figure 8

Clevis- Shackle
Part # RS-1152A
SWL = 32,000 lbs
(14,510 kg.)
Figure 9

Loading

The numbers listed refer to figure 14 and table 1 on pages 7 and 8.

1. Remove gate clip (19).
2. Remove the gate pin (20).
3. Open the loading gate (6 or 9).
4. Load line into groove of wheel (15). See figure 10. Do NOT load the line on top of the shroud that covers the wheel.
5. Close the loading gate, aligning its holes with the holes in the frame (23).
6. Install the gate pin through the holes.
7. Squeeze the gate clip and insert it through the hole in the end of the gate pin.
8. Release the clip and rotate it against the cover. Make sure the clip closes completely. See figure 11.



Properly Loaded Line
Figure 10



Properly Closed Gate
Figure 11

Daily Inspection Checklist

Verify the following. If any discrepancies are noted, remove the sheave from service until repairs are completed. Numbers listed refer to figure 14 and table 1 on pages 7 and 8.

- ❑ All structural components (6 or 9,15,20,23,32,40,52,59,62,64) are not bent, cracked, or otherwise damaged.
- ❑ Loading gate (6 or 9) hinges freely through the fingers in the frame (23).
- ❑ Gate pin (20) can be easily inserted through the holes in the frame (23) and is securely attached with a lanyard (22).
- ❑ Manufacturing tag (17) and safe working load tag (42) are in place and are readable.
- ❑ Inspection tag (29) is in place on the cover and stamped with an inspection date no greater than one year old.
- ❑ Spiral pins (34) are in place and securely retain the axle nuts (33,35) on the axle (32).
- ❑ Wheel (15) rotates freely and smoothly, check for any grinding or sticking, indicating damaged bearings.
- ❑ Gate pin (20) and gate clip (19) are undamaged, lock positively, and are securely attached with lanyards (22).
- ❑ Clevis (64) pivots freely and does not have excessive slop (more than 1/8").
- ❑ Both setscrews (58) are in place and the clevis (64) is secure in the clevis housing (59).
- ❑ Cotter pin (51) is securely retaining the clevis nut (52).

Preventative Maintenance

WTI suggests the following service. Numbers listed refer to figure 14 and table 1 (pg 7-8).

- ❑ The wheel bearings (11) of the orange sheaves are shielded and should be re-greased at least once a month, more often in wet or dusty environments. Always re-grease after pressure washing. Grease is injected through a fitting in the wheel, accessed through a hole in the cover. See figure 12. Use lithium based No.2 EPHT grease, such as Conoco's Tacna® RX. Make sure enough grease is used to extrude past both front and rear shields (10). The smaller holes on each side of the cover are for checking this.
- ❑ The wheel bearings of the yellow sheaves are sealed and only need annual re-packing. This service can be performed at the same time as the annual recertification. See page 6.
- ❑ Monthly, squirt some light machine oil on the hinge pin (between the fingers of the gate frame (40) and the loading gate (6 or 9), and onto the gate pin (20).

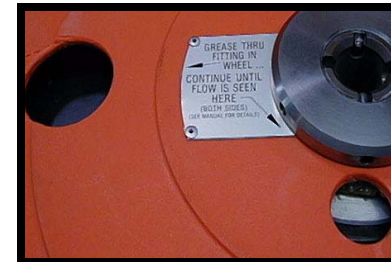

Greasing Holes
Figure 12

Recertification and Repairs

WTI highly recommends yearly recertification of all rigging sheaves, hanger bars, and clevis pins. Most wireline servicing companies mandate annual recertifications so this should not be overlooked. A tag on the front of the cover, shown in figure 13, provides a visible place to stamp certification dates. When a new sheave is placed into service, stamp the current date into this tag. When the date becomes a year old, the sheave should be re-certified. Each time the sheave is re-certified a new date will be stamped in this tag. Upon completion of a repair or recertification, note the information in the log in the back of this manual. Re-certification involves the following:

1. Proof testing.
2. Disassembly.
3. Cleaning
4. NDT inspection of all of the load-bearing components.
5. Replacement or repair of any damaged or worn components.
6. Updating components for safety and easier use.
7. Packing the bearings with grease.
8. Re-assembly.
9. Pre-loading the bearings.
10. Documentation of all changes.
11. Final Inspection.
12. Issuance of a new certification.

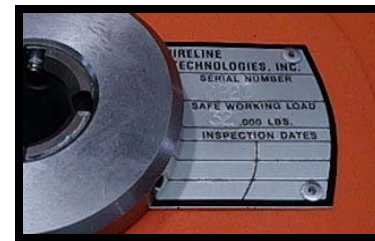

Inspection Tag
Figure 13

Recertification and/or repairs can be done one of three ways.

- Send the sheave to Wireline Technologies, Inc. Please call to make arrangements.
- Send the sheave to an authorized service center. Call to determine the nearest location.
- Determine if your company will allow recertification on site. If so, WTI can supply you with the training and documents needed.

Call Wireline Technologies Inc. (800) 743-2831. Use the drawings in figure 15 on page 7 to identify parts. The numbers in the circles correspond to the item numbers in table 1 on page 8.

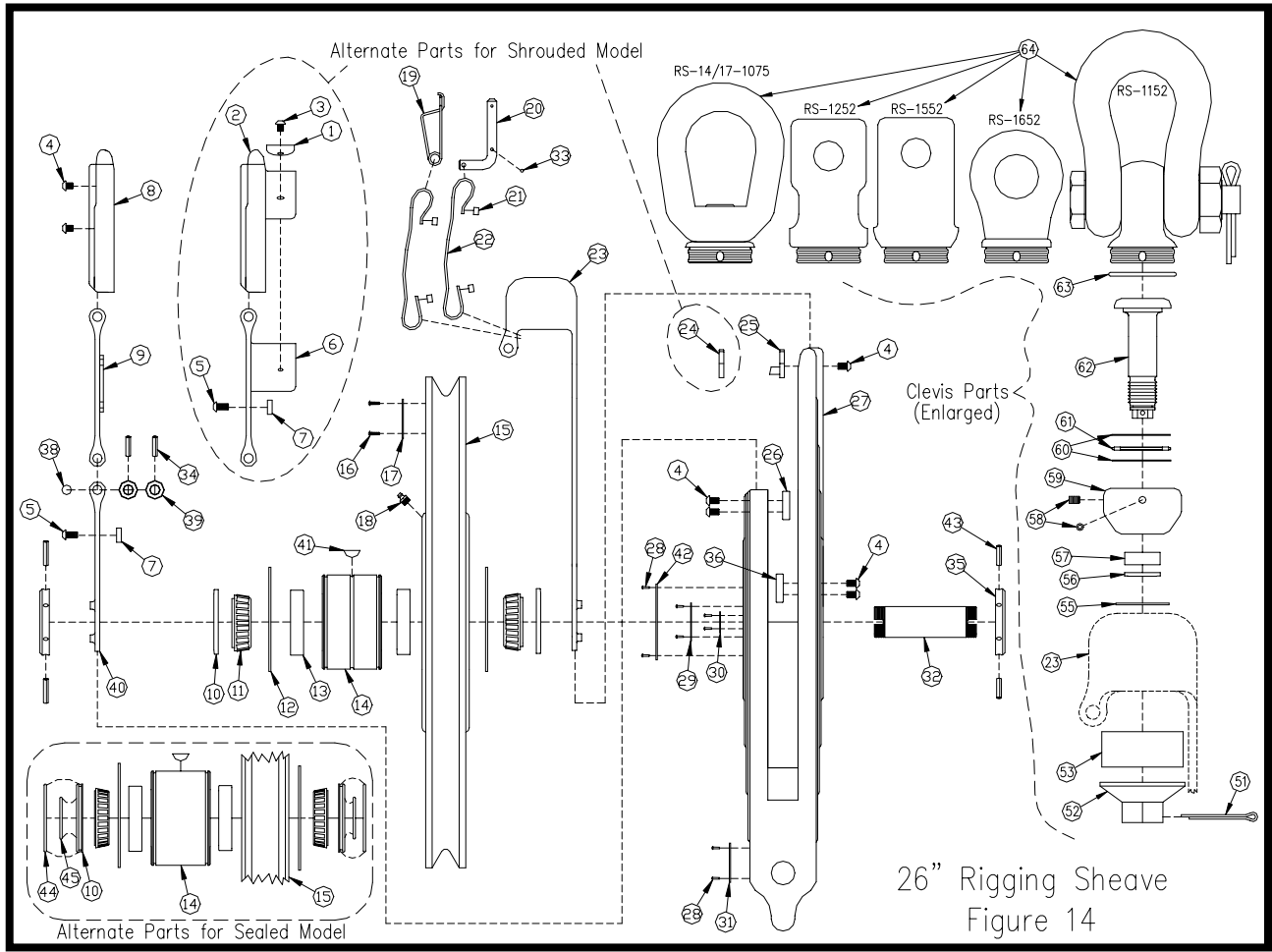

Item	Part Number	Description	Qty. Shrd	Qty. No S	Material
1	RS-1180	Shroud Warning Label	1		Al
2	RS-26-1222-O	Gate Cover - 26", Shrouded	1		X-link Orange
or	RS-26-1222-Y	Gate Cover - 26" Sealed, Shrouded	1		X-link Yellow
3	RS-1066	Button Head Screw 5/16-18 X 3/8"	4		18-8 S/S
4	RS-1065	Button Head Screw 5/16-18 X 1/2"	12	16	18-8 S/S
5	RS-1073	Button Head Screw 5/16-18 X 5/8"	2	2	18-8 S/S
6	RS-26-1007-H	Loading Gate - 26", Half Shroud	1		17-4PH S/S
7	RS-1060	Front Plate	2	1	Anod. Al
8	RS-26-1322-O	Gate Cover - 26", No Shroud		1	X-link Orange
or	RS-26-1322-Y	Gate Cover - 26" Sealed, No Shroud		1	X-link Yellow
9	RS-26-1007-N	Loading Gate - 26", No Shroud		1	17-4PH S/S
10	RS-26-1129	Nilos Grease Ring - 26"	2	2	Galv. Steel
or	RS-26-1067S	O-ring Seat - 26"	2	2	H Anod. Al
11	RS-26-1184	Bearing Cone - 26"	2	2	Alloy Steel
12	RS-26-1012	Retaining Ring - 26"/36"	2	2	Steel
13	RS-26-1183	Bearing Cup - 26"	2	2	Alloy Steel
14	RS-26-1045	Wheel Hub - 26"	1	1	Anod. Al
or	RS-26-1045S	Wheel Hub - 26" Sealed	1	1	H. Anod. Al
15	RS-26-1008-XX	Sheave Wheel - 26"	1	1	Composite
or	RS-26-1008S-XX	Sheave Wheel - 26" Sealed (XX = dash number for groove)	1	1	Composite
16	RS-1071	Drive Screw #6 X 3/8"	4	4	18-8 S/S
17	RS-26-1077	Manufacturing Label - 26"	1	1	Laminate
18	RS-1039	Grease Fitting 1/8" NPT (Not on sealed model)	1	1	Zinc Steel
19	RS-1416	Gate Clip	1	1	302 S/S
20	RS-1216	Gate Pin	1	1	17-4PH S/S
21	RS-1032	Ferrule	4	4	Copper
22	RS-1031	Lanyard	2	2	18-8 S/S
23	RS-26-1028	Frame - 26"	1	1	17-4PH S/S
24	RS-1061	Rear Plate	1		Anod. Al
25	RS-1161	Rear Plate W/ Tab (No Shroud)		1	Anod. Al
26	RS-26-1063	Side Plate	2	2	Anod. Al
27	RS-26-1122-O	Frame Cover - 26"	1	1	X-link Orange

Item	Part Number	Description	Qty. Shrd	Qty. No S	Material
28	RS-1090	Blind Rivet 1/8" X 1/2"	12	12	Al
29	RS-1179	WTI Inspection Label	1	1	Al
or	RS-26-1079	Baker Atlas Inspection Label	1	1	Al
30	RS-1280	Grease Warning Label - 17"/26"	1	1	Al
31	RS-1080	Handle Warning Label	1	1	Al
32	RS-1109	Axle Shaft	1	1	17-4PH S/S
33	RS-1316	Spiral Pin 5/32" X 3/4"	1	1	420 S/S
34	RS-1172	Spiral Pin 1/4" X 1"	2	2	420 S/S
35	RS-1011A	Axle Nut - Adjustable	2	2	303 S/S
36	RS-1062	Stand-Off Pad	2	2	Anod. Al
38	RS-1105	Hinge Pin	1	1	17-4PH S/S
39	RS-1006	Collar	2	2	303 S/S
40	RS-26-1024	Gate Frame - 26"	1	1	17-4PH S/S
41	RS-1010	Woodruff Key #807	1	1	316 S/S
42	RS-26-1380	SWL Label (not on BA)	1	1	Laminate
43	RS-1272	Spiral Pin 1/4" X 1 1/4"	4	4	420 S/S
44	RS-26-1048	O-ring - 26", Outer	2	2	Buna N
45	RS-26-1049	O-ring - 26", Inner	2	2	Buna N
51	RS-1278	Cotter Pin 5/32" X 2"	1	1	316 S/S
52	RS-1055	Clevis Nut	1	1	17-4PH S/S
53	RS-1218	Shock Cushion - 1 1/4" Thick	1	1	Buna N
55	RS-1020	Clevis Washer	1	1	Nylon
56	RS-1057	Clevis Bearing Seal	1	1	Buna N
57	RS-1056	Clevis Bearing	1	1	Alloy Steel
58	RS-1068	Set Screw - Cup 1/4"-20 X 3/8"	2	2	Zinc Alloy
59	RS-1053	Clevis Housing	1	1	17-4PH S/S
60	RS-1058	Thrust Washer	2	2	Alloy Steel
61	RS-1059	Thrust Bearing	1	1	Alloy Steel
62	RS-1154	Clevis Shaft	1	1	17-4PH S/S
63	RS-1098	O-Ring	1	1	Viton
64	RS-14/17-1075	Clevis - EYE	1	1	Weldment
or	RS-1252	Clevis - AWS	1	1	17-4PH S/S
or	RS-1552	Clevis - HLS	1	1	17-4PH S/S
or	RS-1652	Clevis - SJ	1	1	17-4PH S/S

| or | RS-26-1122-Y | Frame Cover - 26" Sealed | 1 | 1 | X-link Yellow | | or | RS-1152 | Clevis - Shackle | 1 | 1 | Assembly |

Table 1. Bill of Materials

Clevis Pin

Two pins are approved for attachment to a clevis. Clevis Pin Kit - SJ, shown in figure 15, is 1.5" in diameter and is to be used with Clevis-SJ. Clevis Pin Kit, shown in figure 16, is 1" in diameter and is to be used with Clevis-AWS or Clevis-HLS. Both of these pins are manufactured from precipitation hardened, high strength, stainless steel alloy. These clevis pins are load bearing and should be re-certified annually with the rigging sheave.

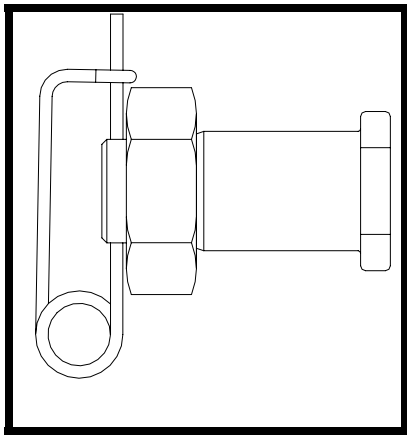

Clevis Pin Kit – SJ
Part # RS-1699
Figure 15

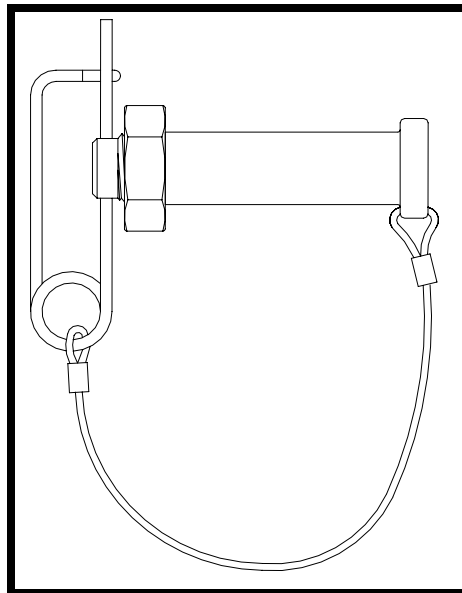

Clevis Pin Kit
Part # RS-1899
Figure 16

Instructions for Use

1. Insert the pin through the clevis and the hanger bar or chain to be attached.
2. Thread the nut onto the end of the pin.
3. Install the safety clip through the hole in the end of the pin and lock it in place.

Hanger Bar

The hanger bar hangs from a crown block or elevator and provides a place to attach the rigging sheave. See figure 17. For use with Clevis-SJ, order Part # SH-100, hole (D) is 1.56". For use with Clevis-AWS or Clevis-HLS, order Part # SH-200, hole (D) is 1.06". The hanger bar bears the same loads as the rigging sheave and should be re-certified annually.

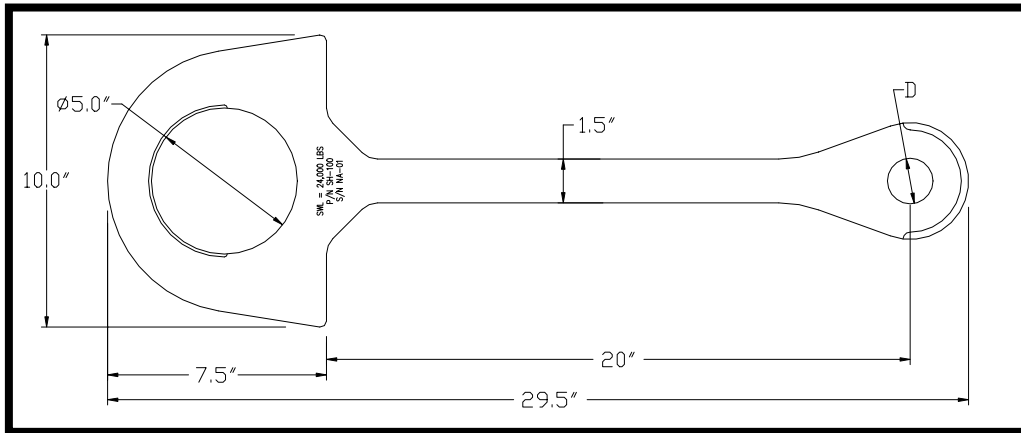

Hanger Bar, Figure 17

Instructions for Use

1. Install the hanger bar in a safe position.
2. Line the holes in the clevis up with the hole in the end of the hanger bar.
3. Insert an approved pin, shown on page 9, through the holes.
4. Properly lock the pin in place.

Hand Guard

Perhaps the most important accessory to a rigging sheave is the hand guard. The hand guard helps prevent accidental entanglement of personnel into the sheave wheel. It is also very helpful at directing the line into the wheel groove to prevent jumping. See figure 18. A hole in the bushing allows the line to pass, but larger objects such as hands and clothing are stopped. The hand guard features split bushings and slotted blocks so it installs quickly and can be left in place when the sheave is not in use. See figure 19 on page 12.



Hand Guard, Part # HG-26-100
Figure 18

Instructions for Use

1. Remove the split bushings by unthreading them from the blocks.
2. Install the arms on either side of the sheave so the holes in the hinges line up with the holes in the axle shaft.
3. Insert the pivot pin through one of the hinges, then the axle, and then the other hinge.
4. Thread the slotted nut onto the end of the pivot pin.
5. Install the cotter pin through the hole in the pivot pin then spread the ends to secure. See figure 20 on page 12.
6. Pull the bushing apart then re-assemble them around the wireline. See figure 19 on page 12.
7. Thread the bushings back into the blocks.

Maintenance

- ◇ Replace the split bushings if the holes wear close to the threads.
- ◇ Lubricate the hinges with light machine oil to keep them moving freely.

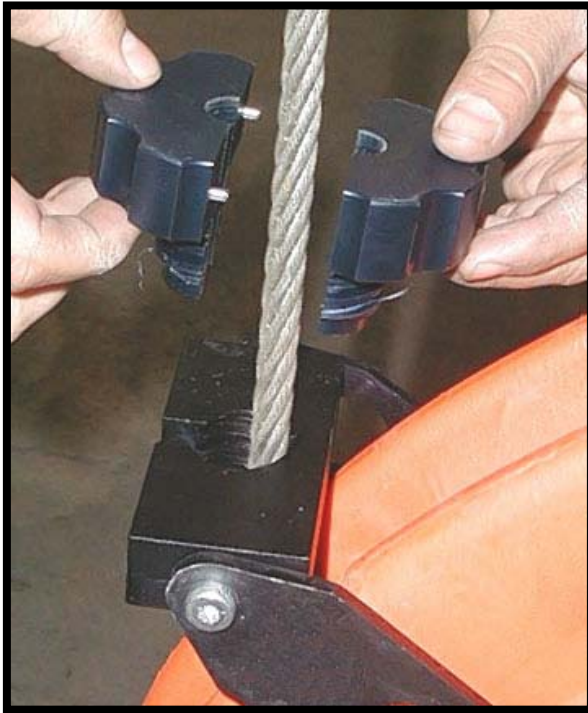

Split Bushing
Figure 19

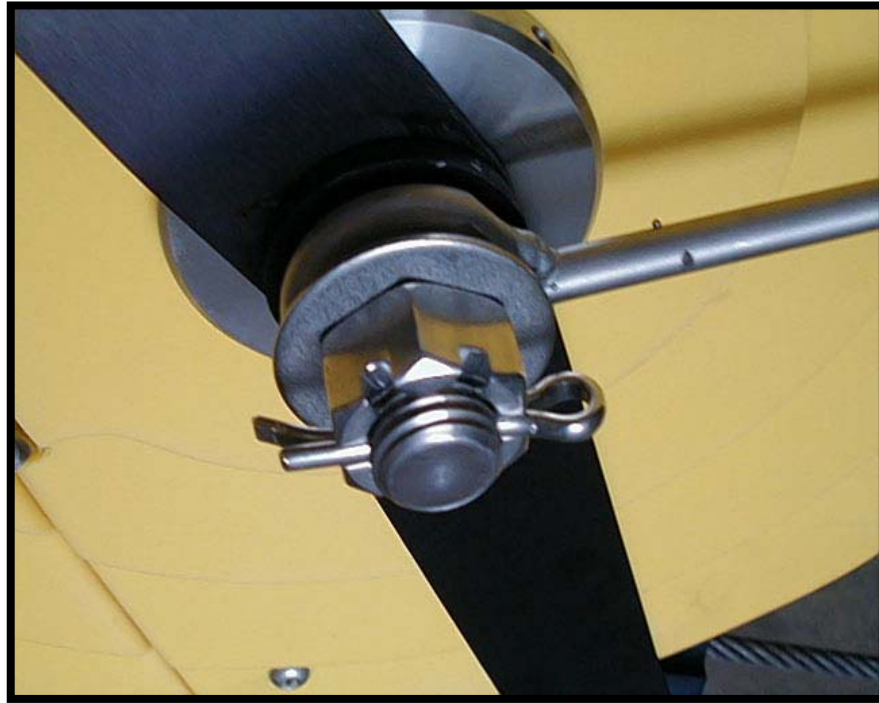

Properly Locked Pivot Pin
Figure 20

Floor Stand

The floor stand is used to keep the sheave upright and in position when the line is slack. Figure 22 shows a sheave mounted in a floor stand. A floor stand can be used with a hand guard. Because the floor stand is open on one side, the line can be loaded into the sheave after the floor stand has been attached. See figure 23.



Floor Stand, Part # FS-100
(Shown with Hand Guard)
Figure 22



Floor Stand
(Open Side)
Figure 23

Instructions for Use

1. Slide the sheave onto the protruding pin of the floor stand.
2. Place the collar on the end of the pin.
3. Align the holes in the collar with the hole in the end of the pin.
4. Install the safety clip through the holes and lock it in place.

Rig-up Yoke

The rig-up yoke is used to lift the rigging sheave into position or to stabilize the sheave when in use. Figure 21 shows a yoke being used to stabilize a rigging sheave. A rig-up yoke can be used with or without a hand guard.

Instructions for Use

1. Install the yoke on either side of the sheave so the holes line up with the hole in the axle shaft. When used with a hand guard, position the hand guard arms inside of the rig-up yoke.
2. Insert the pivot pin through the holes and out the other side of the yoke.
3. Thread the slotted nut onto the end of the pivot pin.
4. Install the cotter pin through the hole in the pivot pin then spread the ends to secure. See figure 20 on page 12.
5. Secure the yoke to hold the sheave in the desired position.



Rig-Up Yoke, Part # RYA-100, Figure 21

Warnings

- Never use the rig-up yoke as a substitute for the clevis. It is not designed to hold loads.
- Never pull the sheave to the side with the rig-up yoke. Always keep it aligned with the wireline.
- Never pull on the rig-up yoke harder than is required to hold the sheave in position.

Storage Rack

A storage rack, sometimes called a truck stand, is a convenient device to hold a sheave secure while traveling. See figure 24.

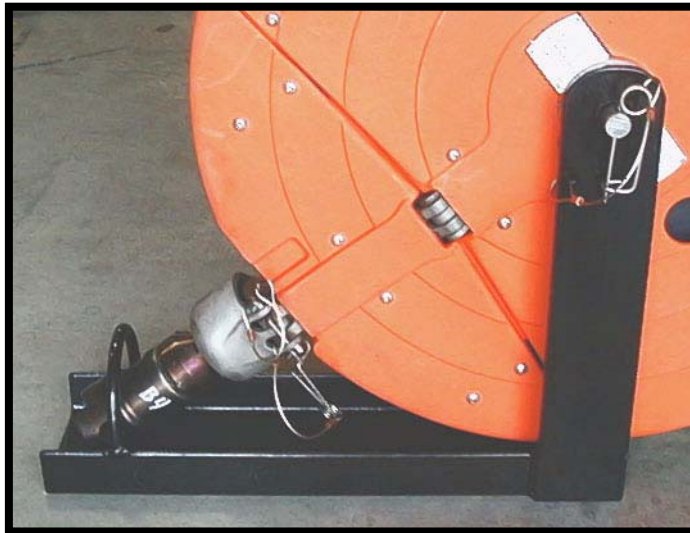

Storage Rack, Part # TS-26-100
Figure 24

Instructions for Use

1. Position the clevis under the loop.
2. Rest the axle nuts of the sheave in the V shaped supports.
3. Install the pin through the supports and the center of the sheave.
4. Install the safety clip through the hole in the end of the pin and lock it in place.

Warranty

For a period of one year from the date of purchase, Wireline Technologies, Inc., will repair or replace, at its option, any 26” rigging sheave of its manufacture that fails because of a defect in materials or manufacture, or which fails to conform to any implied warranty not excluded herein. This warranty does not cover damages caused by abuse, misuse, neglect, or overloading; and does not cover any incidental damages caused by a failure of this product.

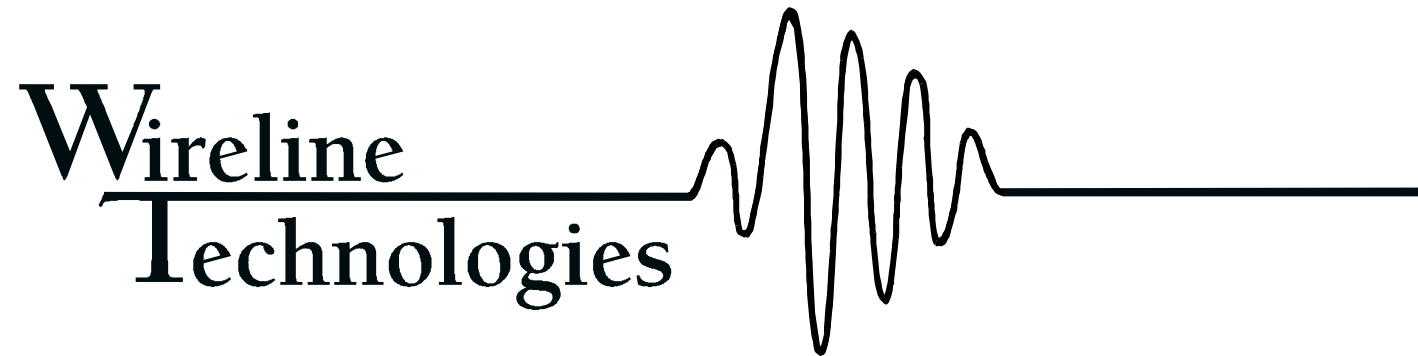

Wireline Technologies Inc.
580 North 700 West
North Salt Lake, UT 84054
www.wtisheave.com

(800) 743-2831

Doc. # WTI-52 Rev. 10 (07-Feb-2004)